



NEMA 5-15

TECH-SPEC®

**2-Pole 3-Wire Grounding 15 Amp 125V
 Plugs and Connectors**



5266N



5269N



5965B



5156HVO



5295



B5295T

Features - Specifications

PLUGS AND CONNECTORS

- Impact/chemical-resistant nylon/polymer construction with automatic cord grip
- Pre-attached TPE dust seal helps prevent contaminants from entering wiring chamber
- Two quick-fasten captive assembly screws automatically tighten cord grip

- Single side terminal screws reduce wiring time and are color coded for proper terminations
- Transparent terminal cover allows instant visual inspection for proper terminations
- Tapered individual wire pockets help prevent flashover and speed wiring termination
- Strip gauge for accurate wiring
- Clamp-type terminals
- Verified under Fed. Spec. #WC596 (where applicable)
- UL Listed File #E1381 – Guide #AXUT
- CSA Certified File #LR16215 – Guide #20T2
- Complies with NEMA Standards WD-1, WD-6 and UL 498
- NOM
- CE

ATTACHMENT PLUGS AND CONNECTORS

| CATALOG NUMBER | | CORD DIA. | DESCRIPTION |
|----------------|------------|----------------------|--|
| PLUG | CONNECTOR | | |
| 5266N | 5269N | .245-.655 (6.2-16.6) | Black & white nylon/polymer |
| 8266N ① | 8269N ① | .245-.655 (6.2-16.6) | White nylon/polymer, hospital grade |
| 8266T ① | 8269T ① | .245-.655 (6.2-16.6) | Transparent nylon/polycarbonate, hospital grade |
| 8266TSP | 8269TSC | .300-.655 (7.6-16.6) | Black & white nylon, water/dust-tight |
| 5266NSY | 5269NSY | .245-.655 (6.2-16.6) | Sentinel yellow nylon/polymer |
| 5266NCR ② | 5269NCR ② | .245-.655 (6.2-16.6) | Sentinel yellow nylon/polymer, corrosion-resistant |
| 5266NOR | — | .245-.655 (6.2-16.6) | Orange nylon/polymer |
| 5266NB | 5269NB | .245-.655 (6.2-16.6) | Black nylon/polymer |
| 5295 ③ | — | .300-.625 (7.6-15.9) | Angle 12 position, black & white nylon |
| B5295T | — | .300-.625 (7.6-15.9) | Angle 12 position, transparent, nylon/polycarbonate, display pak |
| 8295T ① ③ | — | .300-.625 (7.6-15.9) | Angle 12 position, transparent nylon/polycarbonate, hospital grade |
| 5965BY ③ | 5969BY ③ | .245-.655 (6.2-16.6) | Yellow thermoplastic |
| 5965B ③ | 5969B ③ | .245-.655 (6.2-16.6) | Black thermoplastic |
| 5965BGRY ③ | 5969BGRY ③ | .245-.655 (6.2-16.6) | Gray thermoplastic |
| 5156HVO ③ | 5159HVO ③ | .245-.655 (6.2-16.6) | High visibility orange thermoplastic, display pak |
| 5156HVG ③ | 5159HVG ③ | .245-.655 (6.2-16.6) | High visibility green thermoplastic, display pak |
| 1447BRY ④ | 1547BRY ④ | .300-.655 (7.6-16.6) | Yellow elastomeric, dust-tight |
| 14W47BRY ④ | 15W47BRY ④ | .300-.655 (7.6-16.6) | Yellow elastomeric, watertight |

WEATHER PROTECTIVE BOOTS ⑤⑥

| CATALOG NUMBER | | DESCRIPTION |
|----------------|---------|--|
| BLACK | YELLOW | |
| 5200BPB | 5200BP | Thermoplastic elastomer |
| 5200BCB | 5200BC | Boot for use with 5266N and 5965B series plugs |
| 5200BSRB | 5200BSR | Boot for use with 5269N and 5969B series connectors |
| | | Sealing ring for use with 5200 series connector boot |

PRODUCT DIMENSIONS – () Indicates mm dimensions

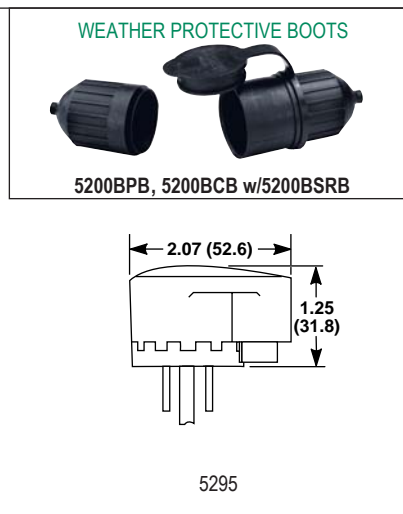
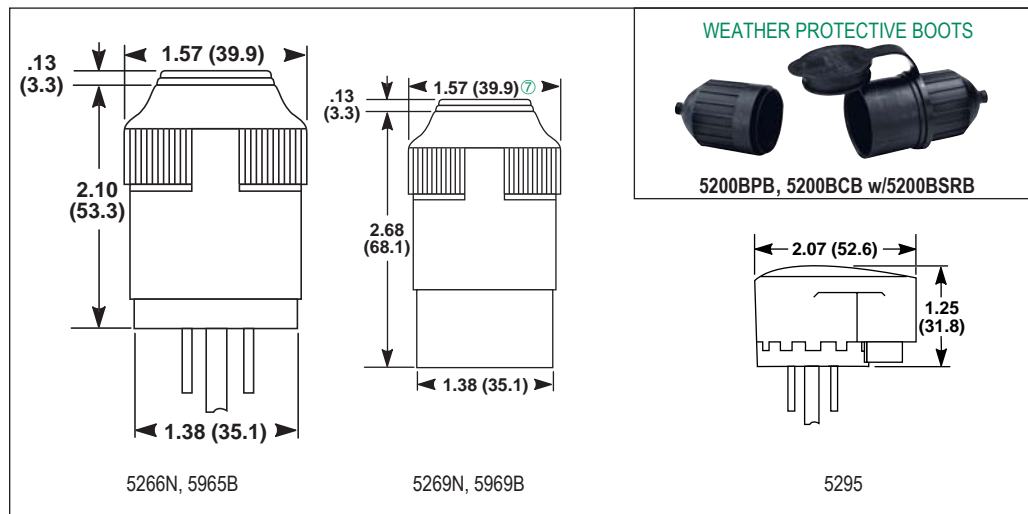

① See page C-7 for hospital grade Features - Specifications.
 ② See page I-3 for corrosion-resistant Features - Specifications.
 ③ Not all TECH-SPEC features apply to these devices. Consult factory.
 ④ See pages I-12, I-13 for water/dust-tight Features - Specifications.
 ⑤ See page I-16 for more information on weather protective boots.
 ⑥ Not UL Listed or CSA Certified.
 ⑦ Dimension is 1.53 (38.9) for catalog numbers 5965B & 5969B. See page P-3 for horsepower ratings. Specifications are subject to change without notice.